



ADJUST

ELECTRIC SIT-STAND BASES



90° Base

TABLE OF CONTENTS

Overview	
Adjust Overview	4
Technical Features	5
Endless Customization	6
2-Stage Bases	
Single Base	9
Straight Base T-Leg	10
Straight Base C-Leg	11
3-Stage Bases	
3-Stage Bases Overview	12
Straight Base C-Leg	14
90° Base	15
Extended L Base	16
120° Base	17
Specifications	
Base Specifications	19
Accessories	
Accessories Overview	22

ADJUST OVERVIEW

ADJUST YOUR MIND, HEALTH AND BODY

Our Adjust Sit-Stand Bases aim to make both standing and sitting a core part of your day. Standing promotes activity and movement, aiding in body circulation and maintaining focus throughout the day.

BASES MAY INCLUDE

+ 3 STAGE LIFT

Quicker, quieter, more range and stability

+ LIFTING CAPACITY

Each sit-stand base conforms to BIFMA standards

+ ANTI-COLLISION

Operate your table worry-free

+ UNMATCHED SAVINGS

Unprecedented Grade 1 & 2 options

+ SPEED

3-Stage Bases rise and lower at 1.25 in/sec

+ OPTIONAL LASER ETCHING

Add a laser etched company logo of your choice on each keypad

+ WIRE MANAGEMENT

Select tables include our Wire Management Tray (additional wire management options available)



Straight Base (3-Stage)

WARRANTY

Open Plan Systems warrants our Sit-Stand Tables to be free of defects in materials and workmanship for as long as the original purchaser owns the product. This warranty extends from the date of installation and is based on normal usage of the product. This warranty does not apply to possible damage or misuse of the product.

Frame	Lifetime
Motors, Electrical & Mechanical Parts	Seven (7) Years

View our full warranty at www.openplan.com.

ELECTRICAL CERTIFICATION

TÜV Rheinland of North America's US certification mark is recognized and accepted by state, city and county regulators (building officials, fire marshals and electrical inspectors) throughout the US. TÜV Rheinland tests to the same specifications as those defined by UL as US standards.



TECHNICAL FEATURES

3-STAGE LIFT

A majority of our Adjust Sit-Stand Bases come standard with a 3-stage lift mechanism. Our 3-stage bases are equipped with quicker and quieter motors to transition from sitting to standing in seconds!

Note: All bases are specified with 2-stage or 3-stage lift mechanisms. To verify lift mechanism, look under the **Motor** section of each description



ANTI-COLLISION TECHNOLOGY
Operate your table worry-free!

BENEFITS OF 3-STAGE LIFT

- ✓ Greater Range
- ✓ Quieter Motor
- ✓ Faster Transition
- ✓ More Stability

LED SMART KEYPAD

With the single press of a button, your table moves to the ideal sitting or standing height of your choosing. The LED Smart Keypad can program four different height positions, so you can save your favorite heights for hassle free use.

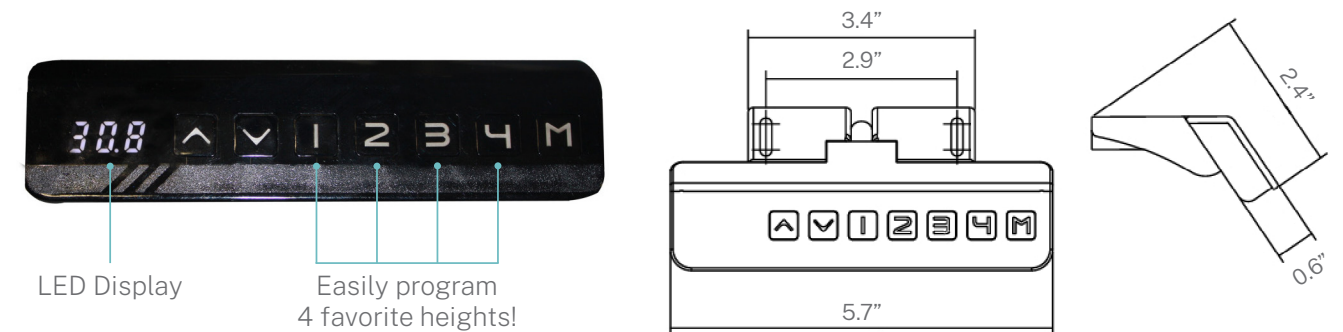

UP/DOWN CONTROL PAD (SINGLE BASE ONLY)

An easy-to-use Up/Down Control Pad helps to make our Single Base a true value option for offices!

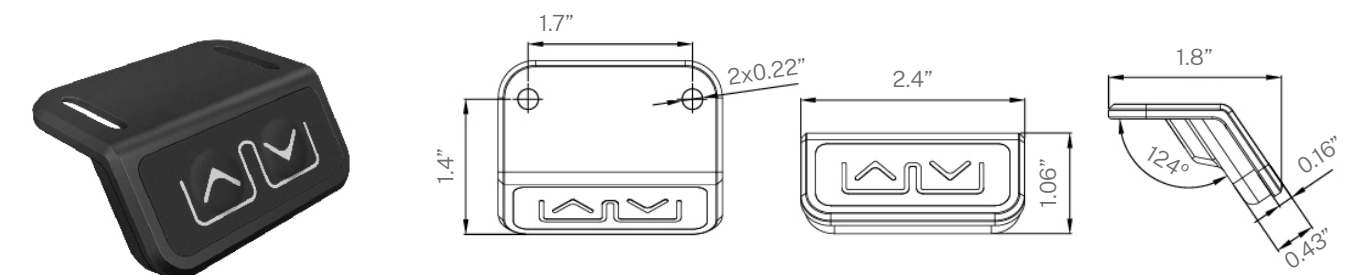

ENDLESS CUSTOMIZATION

Health benefits aside, there is a lot more to our Adjust Bases. Selecting a base is only the beginning. From the numerous finishes, top shapes and sizes and our large number of accessories, our Adjust bases can be personalized to fit into any office environment.

EXCLUSIVE FEATURES



FREE LASER ETCHING

Add your choice of a laser etched company logo on keypad.

NOTE: Not available on Single Base or 2-Stage Straight Base (T-Leg)

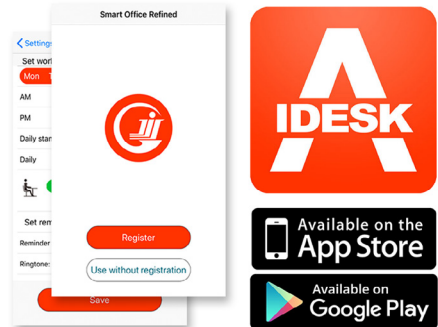

FREE HEALTH APP

Access to Bluetooth enabled health app to track and monitor tables.

NOTE: Requires the purchase of a Bluetooth device.



FREE WIRE MANAGEMENT

Organize any loose wires with our included wire management tray. (E-TABLE-J-WM)

NOTE: Not available on Single Base, 2-Stage Straight Base (T-Leg) Includes slim metal wire tray

FINISH OPTIONS

Base Paints



NOTE: Single Base available in BU only. 2- Stage Straight Base (C-Leg) and 2-Stage Straight Base (T-Leg) BU and MS only.

Work Surfaces

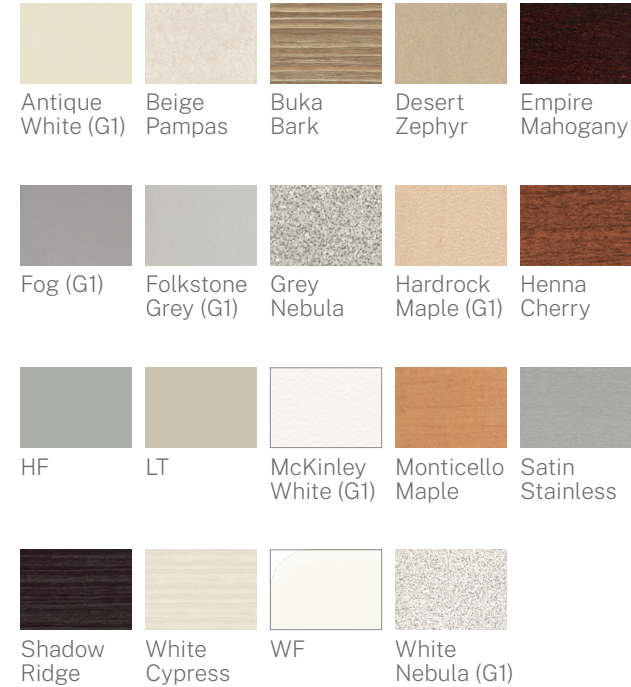

(G1) - Available as Grade 1 work surface

NOTE: Grade 2 work surfaces can be purchased with Grade 1 Bases but the work surface will be at the Grade 2 discount.

A TOP FOR ANY OFFICE

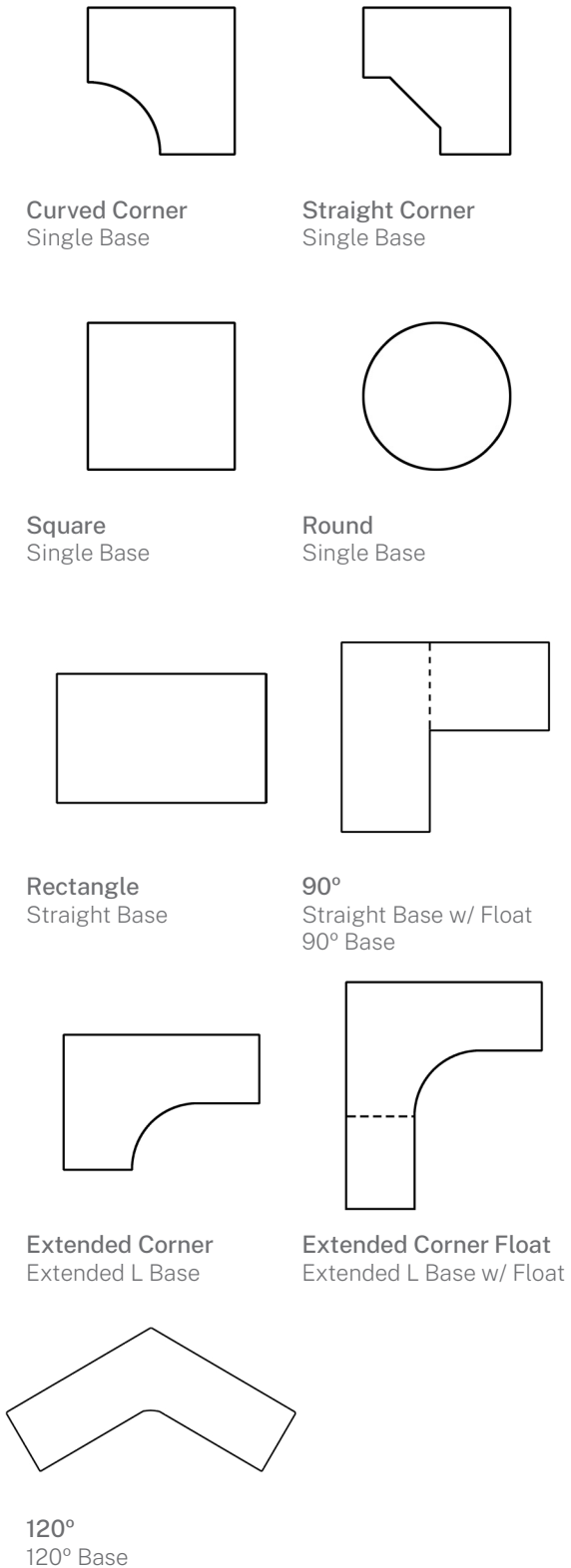

ACCESSORIES



Monitor Arms



Power Duplexes



Keyboard Tray



Wire Management



Casters



Storage



Bluetooth Device

See pg. 22 to learn more about our accessory options.



Razor System Panels / 90° Base

SINGLE BASE

2-STAGE



E-TABLE-CORNER.BU

Tops sold separately.

FEATURES

Keypad	Push Button
Motor	2-Stage Lift / Single Motor
Foot Style & Length	Angled Construction - 24" D
Height Range (excl. top)	27.2" to 44.9"
Top Options	Curved Corner, Straight Corner, Square and Round
Work Surface Widths	36" and 42"
Work Surface Depths	24" and 30"
Max Lifting Capacity	180 lbs total
Speed	0.8 in/sec (20 mm/sec)
Anti-Collision	Yes
Assembly	Standard construction
Keypad Logo Laser Etching	N/A
Free Health App	N/A
Wire Management	Sold separately
Discount Level	Grade 1

TOP OPTIONS

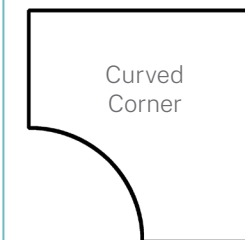

Curved Corner

36x36x24, 36x36x30
42x42x24, 42x42x30

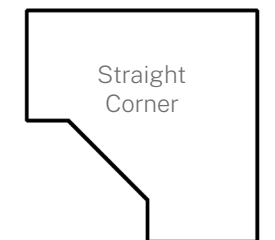

Straight Corner

36x36x24, 36x36x30,
42x42x24, 42x42x30

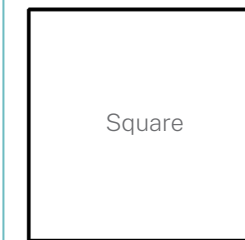

Square

36x36, 42x42

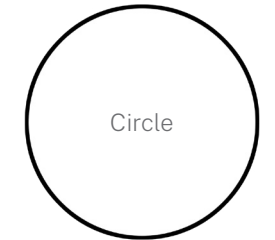

Circle

36, 42

NOTE: Corner grommets (GRCUT) do not come standard on sit-stand base tops (AHCWS, AHCCWS, AHTECCWS) and must be specified separately.

STRAIGHT BASE

2-STAGE T-LEG



E-TABLE-2S-T-LEG.XX

XX denotes paint color.
Tops sold separately.

FEATURES

Keypad	LED Display/Push Button/3 Memory Heights
Motor	2-Stage Lift / Dual Motor
Foot Style & Length	T-Leg - 23.6"
Height Range (excl. top)	27.2" to 46.5"
Work Surface Widths	42" to 84"
Work Surface Depths	24" to 36"
Max Lifting Capacity	220.5 lbs per leg
Speed	1.26 in/sec (32 mm/sec)
Anti-Collision	Yes
Assembly	Easy fold out legs
Keypad Logo Laser Etching	N/a
Free Health App	N/a
Wire Management	Wire Tray included / Additional sold separately
Discount Level	Grade 1

ADDITIONAL FEATURES



QUICK ASSEMBLY

Comes with easy assembly foldout legs!



ADJUSTABLE FRAME

Designed to accommodate the perfect width top for your office.



KEYPAD WITH STANDING

REMINDERS

designed to include three programmable heights, anti-collision technology, and a new reminder function to help you stay on track with your sitting and standing goals.

STRAIGHT BASE

2-STAGE C-LEG



E-TABLE-2S-48-72-J.XX

XX denotes paint color.
Tops sold separately.

FEATURES

Keypad	LED Display / Push Button / 4 Memory Heights
Motor	2-Stage Lift / Dual Motor
Foot Style & Length	C-Leg - 22.83"
Height Range (excl. top)	27" to 46.7"
Work Surface Widths	42" to 78"
Work Surface Depths	24" to 36"
Max Lifting Capacity	281 lbs total (BIFMA standards for a 30 x 72 table is 225 lbs total)
Speed	1.26 in/sec (32 mm/sec)
Anti-Collision	Yes
Assembly	Standard Construction
Keypad Logo Laser Etching	Available
Free Health App	Available / Bluetooth adapter sold separately
Wire Management	Wire Tray included / Additional sold separately
Discount Level	Grade 1

ADDITIONAL FEATURES

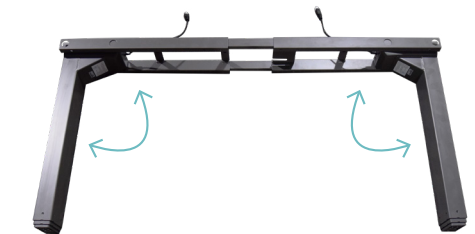

QUICK ASSEMBLY

Comes with easy assembly foldout legs!

3-STAGE BASES

OUR FASTEST & QUIETEST BASES



OPTIONAL FLOAT LEG
(see pg 14 for more info)

STRAIGHT BASE

Keypad	LED Display / Push Button / 4 Memory Heights
Motor	3-Stage Lift / Dual Motor
Foot Style & Length	C-Leg - 22.83"
Height Range (excl. top)	23.6" to 49.2"
Work Surface Widths	42" to 78"
Work Surface Depths	24" to 36"
Max Lifting Capacity	175 lbs per leg (BIFMA standards for a 30 x 72 table is 225 lbs total)
Speed	1.57 in/sec (44 mm/sec)
Anti-Collision	Yes
Assembly	Easy fold out legs
Keypad Logo Laser Etching	Available
Free Health App	Available / Bluetooth device sold separately
Wire Management	Wire Tray included / Additional sold separately
Discount Level	Grade 1



90° BASE

Keypad	LED Display / Push Button / 4 Memory Heights
Motor	3-Stage Lift / Triple Motor
Foot Style & Length	C-Leg - 22.83"
Height Range (excl. top)	23.6" to 49.2"
Work Surface Widths	42" to 72" (Side A) 42" to 48" (Side B)
Work Surface Depths	24" and 30"
Max Lifting Capacity	175 lbs per leg (BIFMA standards for a 30 x 72 table is 225 lbs total)
Speed	1.57 in/sec (44 mm/sec)
Anti-Collision	Yes
Assembly	Easy fold out legs
Keypad Logo Laser Etching	Available
Free Health App	Available / Bluetooth device sold separately
Wire Management	Wire Tray included / Additional sold separately
Discount Level	Grade 1

NOTE: Due to a 3rd motor, the 90° Base requires a cable adapter to use Bluetooth device.



OPTIONAL FLOAT LEG
(see pg 16 for more info)

EXTENDED L BASE

Keypad	LED Display / Push Button / 4 Memory Heights
Motor	3-Stage Lift / Dual Motor
Foot Style & Length	T-Leg - 25.6" (short), 39.4" (long)
Height Range (excl. top)	23.6" to 49.2"
Work Surface Widths	60" to 72"
Work Surface Depths	24", 30" (short), 36" to 48" (long)
Max Lifting Capacity	175 lbs per leg (BIFMA standards for a 30 x 72 table is 225 lbs total)
Speed	1.57 in/sec (44 mm/sec)
Anti-Collision	Yes
Assembly	Standard construction
Keypad Logo Laser Etching	Available
Free Health App	Available / Bluetooth device sold separately
Wire Management	Wire Tray included / Additional sold separately
Discount Level	Grade 2

NOTE: Float Leg add-on provides a third leg and motor to extend the surface area of an Extended L Base. The 3-leg Extended L Base requires a cable adapter to use Bluetooth device.



120° BASE

Keypad	LED Display / Push Button / 4 Memory Heights
Motor	3-Stage Lift / Triple Motor
Foot Style & Length	T-Leg - 27.6"
Height Range (excl. top)	23.6" to 49.2"
Work Surface Widths	42" to 60"
Work Surface Depths	24"
Max Lifting Capacity	175 lbs per leg (BIFMA standards for a 30 x 72 table is 225 lbs total)
Speed	1.57 in/sec (44 mm/sec)
Anti-Collision	Yes
Assembly	Standard construction
Keypad Logo Laser Etching	Available
Free Health App	Available / Bluetooth device sold separately
Wire Management	Wire Tray included / Additional sold separately
Discount Level	Grade 2

NOTE: Due to a 3rd motor, the 120° Base requires a cable adapter to use Bluetooth device.

STRAIGHT BASE

3-STAGE



E-TABLE48-72-J.XX

XX denotes paint color.
Tops sold separately.

FEATURES

Keypad	LED Display / Push Button / 4 Memory Heights
Motor	3-Stage Lift / Dual Motor
Foot Style & Length	C-Leg - 22.83"
Height Range (excl. top)	23.6" to 49.2"
Work Surface Widths	42" to 78"
Work Surface Depths	24" to 36"
Max Lifting Capacity	175 lbs per leg (BIFMA standards for a 30 x 72 table is 225 lbs total)
Speed	1.57 in/sec (44 mm/sec)
Anti-Collision	Yes
Assembly	Easy fold out legs
Keypad Logo Laser Etching	Available
Free Health App	Available / Bluetooth device sold separately
Wire Management	Wire Tray included / Additional sold separately
Discount Level	Grade 1

ADDITIONAL FEATURES

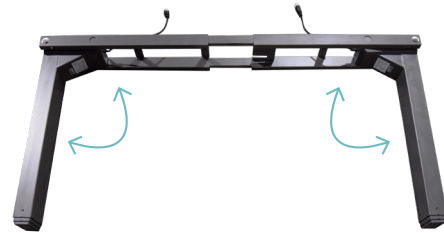

QUICK ASSEMBLY

Comes with easy assembly foldout legs!

OPTIONAL FLOAT LEG E-TABLE90-J.XX

Add a third leg to your base for a larger work space.

If adding to an existing base:

1. Float leg is swapped out with base leg.
2. Base leg is then used for the additional table top support.
3. Original 2-leg controller is replaced with new 3-leg controller.

If purchasing Straight Base and Float Leg together, the 90° Base (all-in-one package) is recommended.

NOTE: Float Leg add-on provides a third leg and motor to transform a Straight Base into a 90° Base. The 90° base requires a cable adapter to use Bluetooth device.



90° BASE

3-STAGE



E-TABLE48-72-90-J.XX

XX denotes paint color.
Tops sold separately.

FEATURES

Keypad	LED Display / Push Button / 4 Memory Heights
Motor	3-Stage Lift / Triple Motor
Foot Style & Length	C-Leg - 22.83"
Height Range (excl. top)	23.6" to 49.2"
Work Surface Widths	42" to 72" (Side A) 42" to 48" (Side B)
Work Surface Depths	24" and 30"
Max Lifting Capacity	175 lbs per leg (BIFMA standards for a 30 x 72 table is 225 lbs total)
Speed	1.57 in/sec (44 mm/sec)
Anti-Collision	Yes
Assembly	Easy fold out legs
Keypad Logo Laser Etching	Available
Free Health App	Available / Bluetooth device sold separately
Wire Management	Wire Tray included / Additional sold separately
Discount Level	Grade 1

ADDITIONAL FEATURES

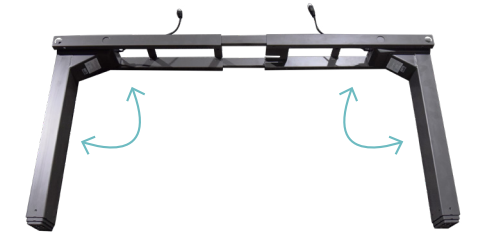

QUICK ASSEMBLY

Comes with easy assembly foldout legs!

NOTE: Due to a 3rd motor, the 90° Base requires a cable adapter to use Bluetooth device.

EXTENDED L BASE

3-STAGE



E-TABLE-L-J.XX

XX denotes paint color.
Tops sold separately.

FEATURES

Keypad	LED Display / Push Button / 4 Memory Heights
Motor	3-Stage Lift / Dual Motor
Foot Style & Length	T-Leg - 25.6" (short), 39.4" (long)
Height Range (excl. top)	23.6" to 49.2"
Work Surface Widths	60" to 72"
Work Surface Depths	24", 30" (short), 36" to 48" (long)
Max Lifting Capacity	175 lbs per leg (BIFMA standards for a 30 x 72 table is 225 lbs total)
Speed	1.57 in/sec (44 mm/sec)
Anti-Collision	Yes
Assembly	Standard construction
Keypad Logo Laser Etching	Available
Free Health App	Available / Bluetooth device sold separately
Wire Management	Wire Tray included / Additional sold separately
Discount Level	Grade 2

ADDITIONAL FEATURES

OPTIONAL FLOAT LEG E-TABLE90-J.XX

Add a third leg to your base for a larger work space.

If adding to an existing base:

1. Float leg is swapped out with base leg.
2. Base leg is then used for the additional table top support.
3. Original 2-leg controller is replaced with new 3-leg controller.

If Float Leg is purchased with base, correct 3-leg controller will automatically be included.



NOTE: Float Leg add-on provides a third leg and motor to extend the surface area of an Extended L Base. The 3-leg Extended L Base requires a cable adapter to use Bluetooth device.

When adding a Float Leg, an additional part must be specified (E-TABLEFT-J) to match the float leg foot to T-Leg style.

NOTE: Corner grommets (GRCUT) do not come standard on sit-stand base tops (AHCWS, AHCCWS, AHTECCWS) and must be specified separately.

120° BASE

3-STAGE



E-TABLE-120-J.XX

XX denotes paint color.
Tops sold separately.

FEATURES

Keypad	LED Display / Push Button / 4 Memory Heights
Motor	3-Stage Lift / Triple Motor
Foot Style & Length	T-Leg - 27.6"
Height Range (excl. top)	23.6" to 49.2"
Work Surface Widths	42" to 60" (42" requires base modification)
Work Surface Depths	24"
Max Lifting Capacity	175 lbs per leg (BIFMA standards for a 30 x 72 table is 225 lbs total)
Speed	1.57 in/sec (44 mm/sec)
Anti-Collision	Yes
Assembly	Standard construction
Keypad Logo Laser Etching	Available
Free Health App	Available / Bluetooth device sold separately
Wire Management	Wire Tray included / Additional sold separately
Discount Level	Grade 2

NOTE: Due to a 3rd motor, the 120° Base requires a cable adapter in order to use Bluetooth device.



Extended L Base

BASE SPECIFICATIONS

SINGLE BASE

E-TABLE-CORNER.BU

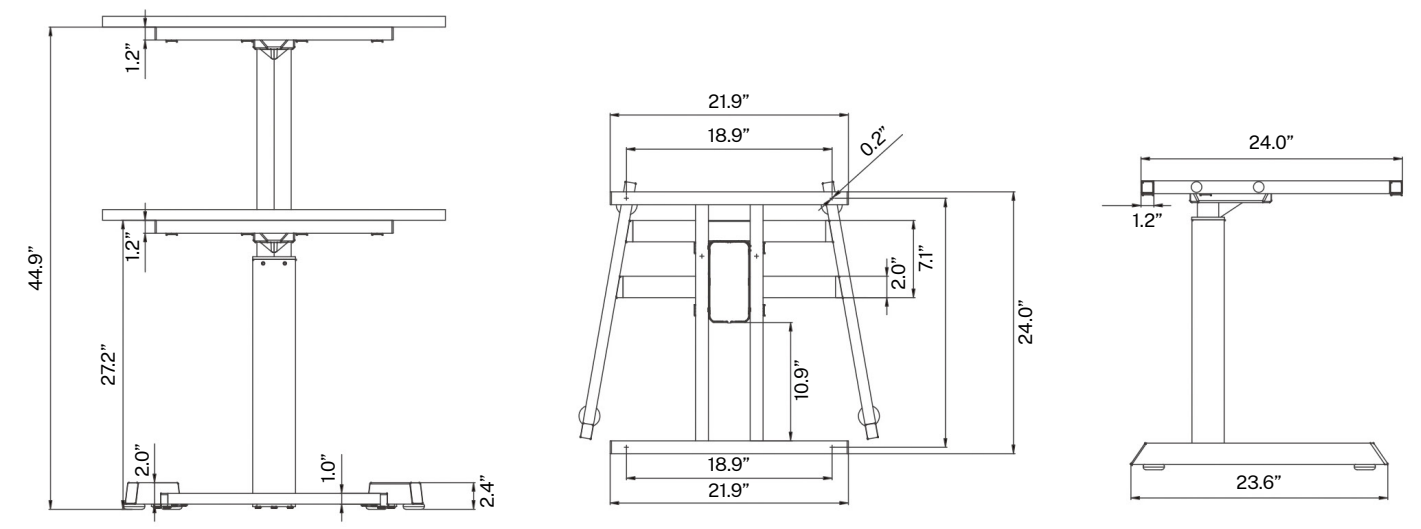

STRAIGHT BASE (2-STAGE) C-LEG

E-TABLE-2S-48-72-J.XX

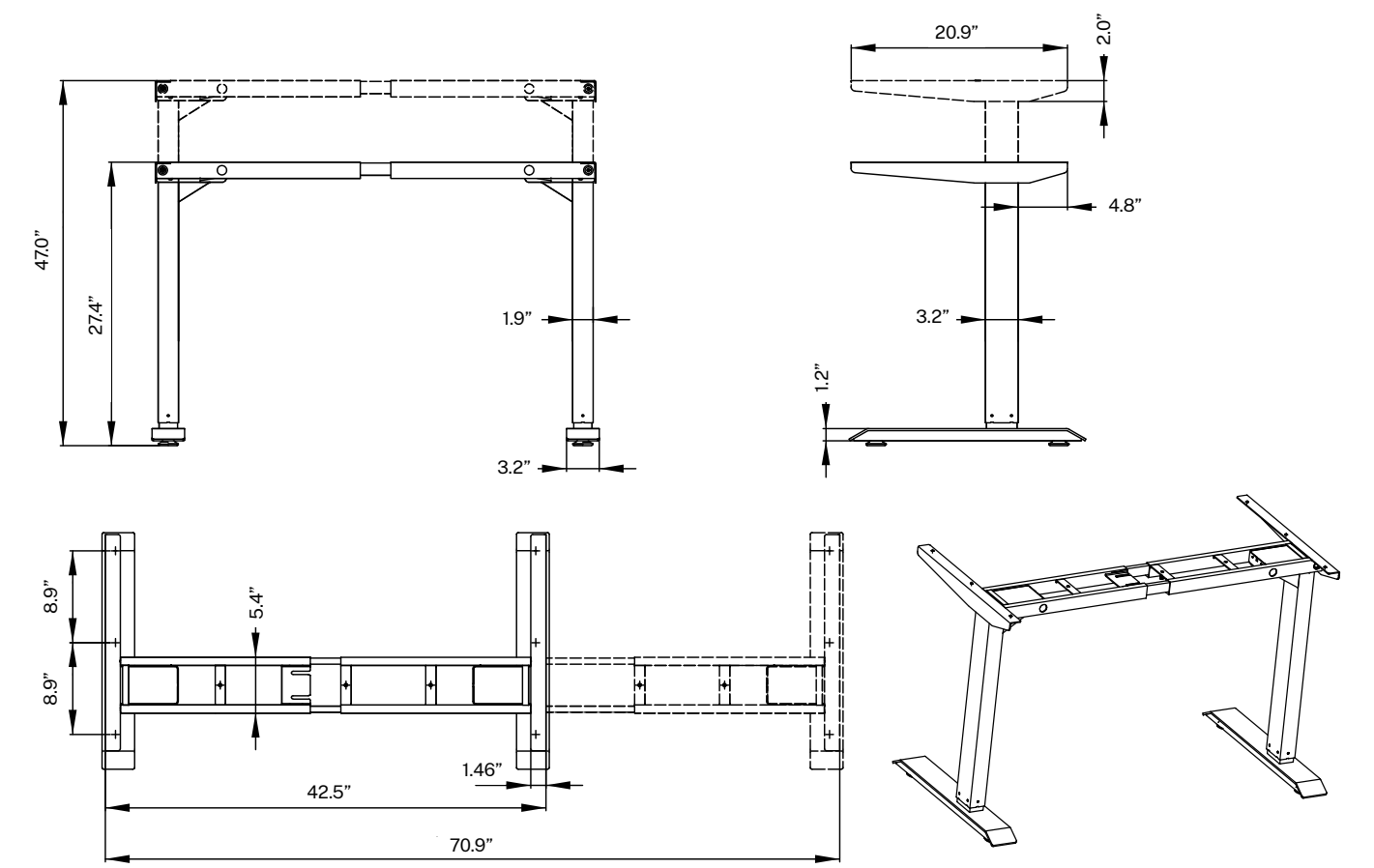

BASE SPECIFICATIONS

STRAIGHT BASE (2-STAGE) T-LEG

E-TABLE-2S-T-LEG.XX

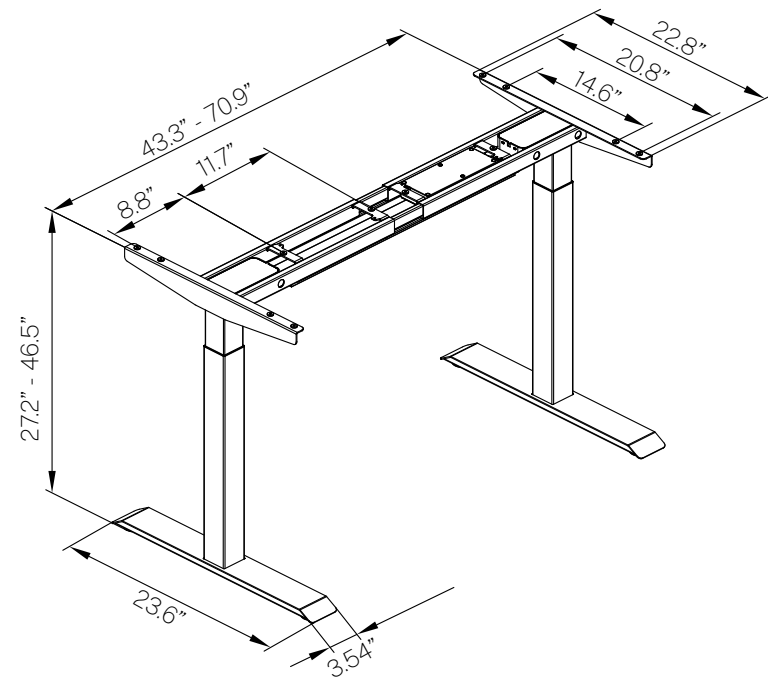

EXTENDED L BASE

E-TABLE-L-J.XX

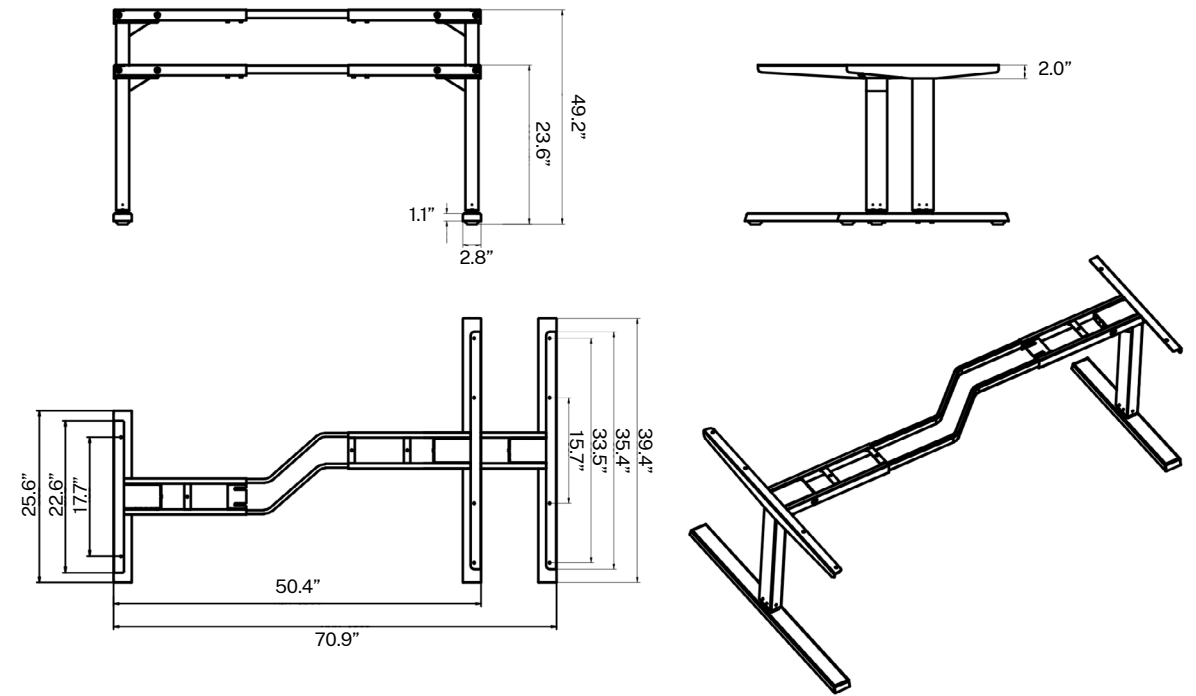

STRAIGHT BASE (3-STAGE) 90° BASE

E-TABLE48-72-J.XX
E-TABLE48-72-90-J.XX

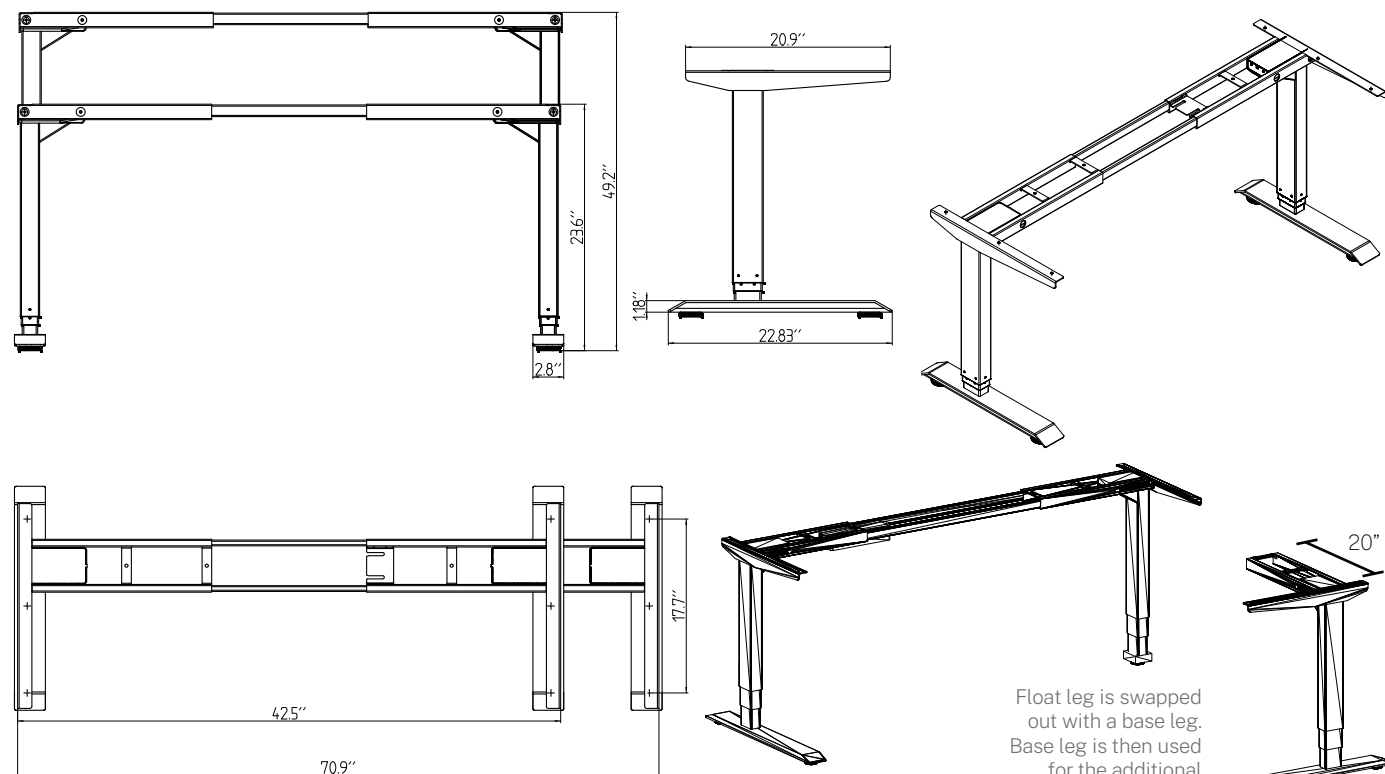

Float leg is swapped out with a base leg. Base leg is then used for the additional table top support.

120° BASE

E-TABLE-120-J.XX

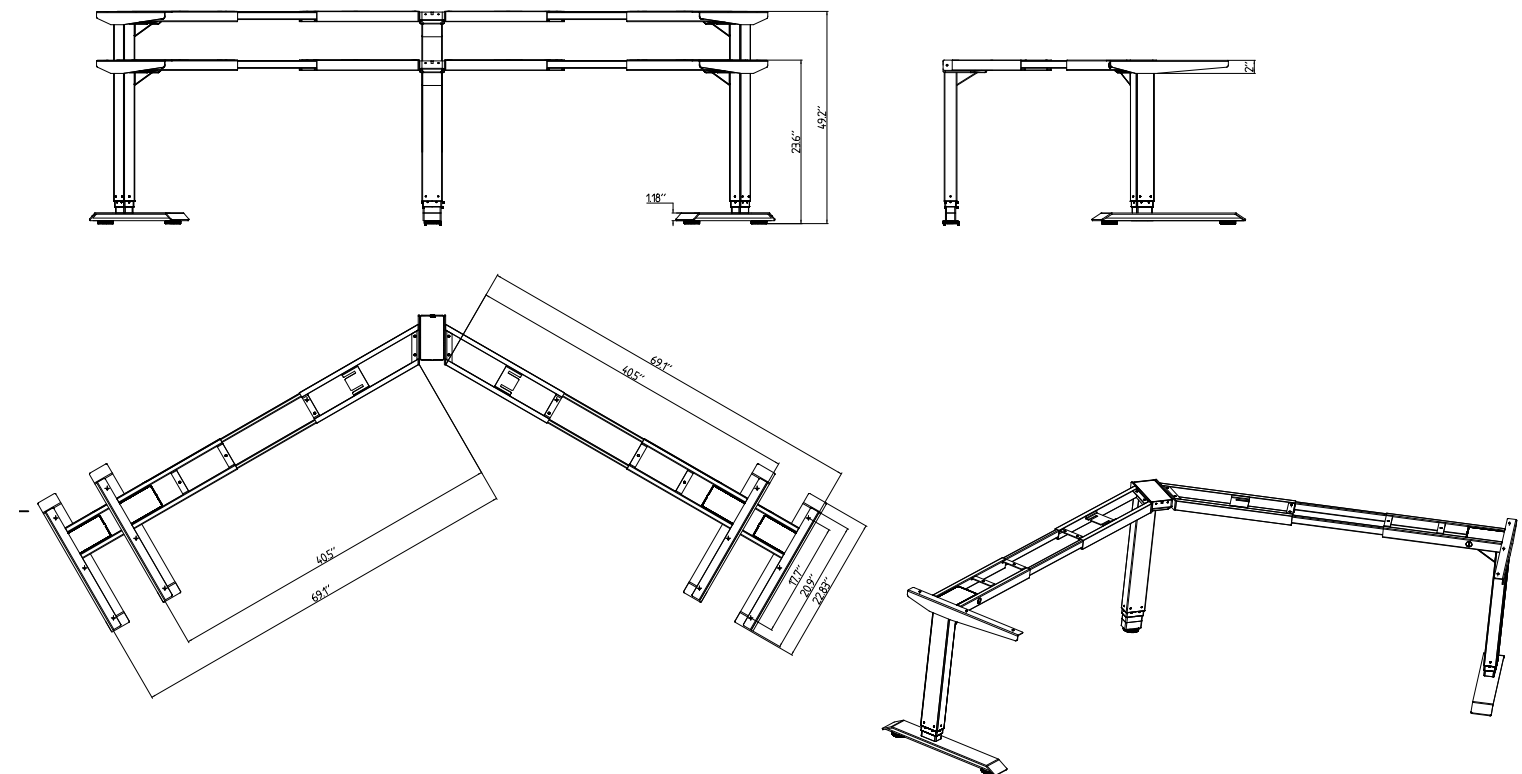

ACCESSORIES OVERVIEW

CUSTOMIZE YOUR SIT-STAND STATION

Personalize each base with our extensive selection of ergonomic accessories.



MONITOR ARMS
Clamp or Grommet

POWER DUPLEXES
with USB charging

KEYBOARD TRAY

WIRE MANAGEMENT OPTIONS

CUSHIONED MOBILE PEDESTAL

STORAGE AND SCREENS



DESK SCREEN DIVIDER
DSDXX.F
For width, replace XX with 24, 30, 36, 42, 48, 60 or 72

MOBILE PEDESTAL
DS-BF-FP-M
Seat Cushion sold separately (DS-SC15)



MONITOR ARMS



BUDGET SINGLE ARM
OPS-101-BUDGET
Clamp and grommet style included.



STANDARD SINGLE ARM
WKTREX (Clamp Mount)
WKGRTREX (Grommet Mount)



PREMIUM SINGLE ARM
OPS-101.XX
Available in Black (.BU) or White Frost (.WF)
Clamp and grommet style included.



BUDGET DUAL ARM
OPS-201-BUDGET
Clamp and grommet style included.



STANDARD DUAL ARM
WKTREX2 (Clamp Mount)
WKGRTREX2 (Grommet Mount)



PREMIUM DUAL ARM
OPS-201.XX
Available in Black (.BU) or White Frost (.WF)
Clamp and grommet style included.

ERGONOMICS



KEYBOARD TRAY
WKETABLE
Designed for 30" and 36" D Straight Powered Adjustable Height Tables only.



BLUETOOTH ADAPTER
E-TABLE-J-BLUETOOTH
Cable adapter required for 3-leg bases (E-TABLE-J-BLUETOOTH-ADAPTER).



LEG CASTERS
E-TABLE-CASTER-1
Set of four (4) included.

POWER OPTIONS



PLUG-IN USB DUPLEX
XP-DUPLEX-USB-P-1.XX
Available in Black (.BU) or White (.WH)



WIRE MANAGEMENT TRAY
E-TABLE-J-WM
One tray is included with each Adjust Base purchase (Single Base excluded)

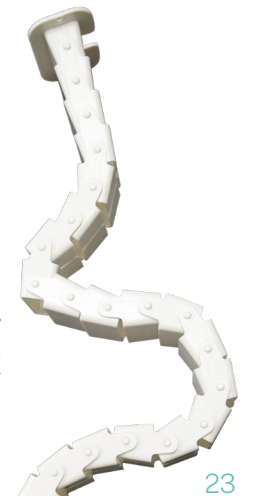

53" WIRE MANAGEMENT
WM-E.XX
Available in Black (.BU) Metallic Silver (.MS) and White Frost (.WF)



www.openplan.com | sales@openplan.com | 844.OPS.OPS1 | REV 07.27.21

© 2021 Open Plan Systems. All Rights Reserved.

All content is subject to change. For the most current revision, visit www.openplan.com.