



GROMMET

PLACEMENT GUIDE

TABLE OF CONTENTS

INTRODUCTION

How Grommets Are Placed.....3

DESKTOP POWER

Standard Grommet.....4
Data/Power Unit5
Recessed Power Strip6
Recessed Power Strip CAT67
Covered Data/Power Unit.....8
Wireless Charger.....9
Pop-Up Table Dock10

WORK SURFACE PLACEMENT

Sixty-Five Tops11
XPand Tops.....13

HOW GROMMETS ARE PLACED

Dimensions run from the end of the surface to the center of the grommet cutout. To determine the location of a CENTER grommet, divide work surface length by 2. To determine the location of a LEFT or RIGHT grommet, divide work surface length by 4. Corner and depth dimensions are standard as shown below.

SAMPLE SURFACE

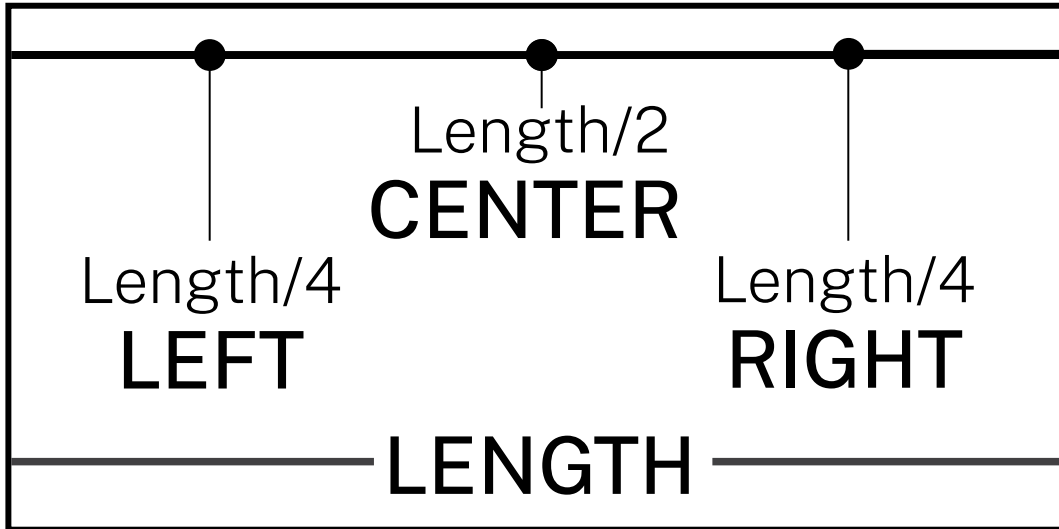

NOTE: Left and Right measurements are taken from the nearest end. Any dimension under 15" from edge is not recommended when using with pedestal.

HOW SCALLOP CUTS ARE PLACED

Dimensions run from the end of the surface to the center of the scallop cutout. To determine the location of a CENTER scallop, divide work surface length by 2. To determine the location of a LEFT or RIGHT scallop, divide work surface length by 4. All scallop cuts are along the edge of the work surface and 7.808" wide and 2" deep as shown below.

SAMPLE SURFACE

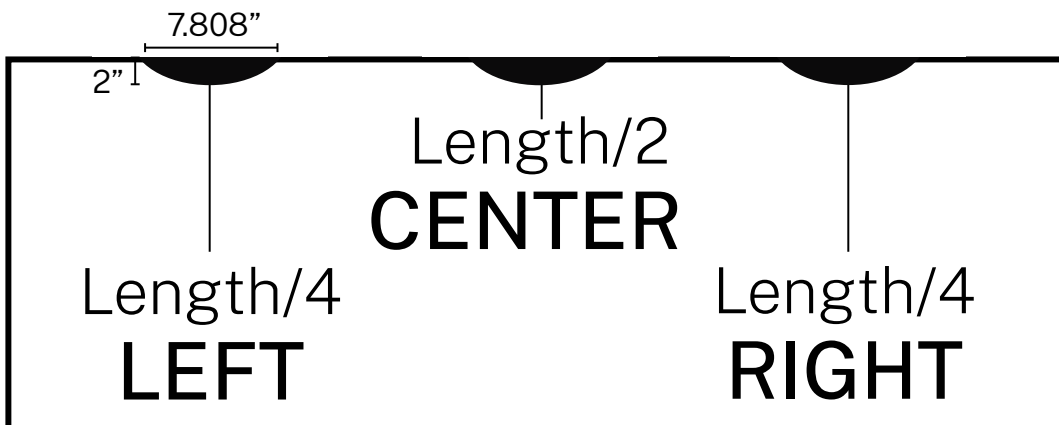

NOTE: Scallop cuts (SRCUT) come standard on all Sixty-Five work surfaces and are available as options on other system work surfaces.

SKU: GRCUT



Surface Diameter: 2.8"
Cutout Diameter: 2.39"

1. STRAIGHT

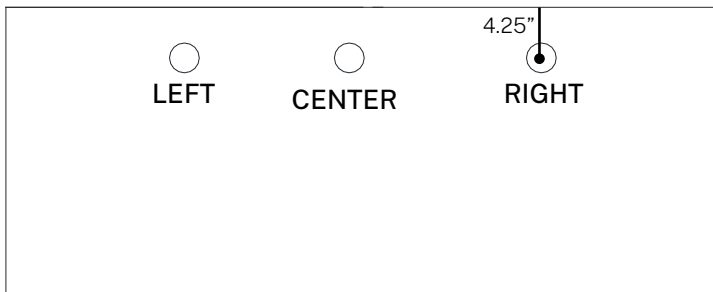

NOTE: Rectangular work surfaces do not come standard with grommets, they are by request only. Center grommet not applicable with center cantilever on tops 60" and larger.

2. CORNER

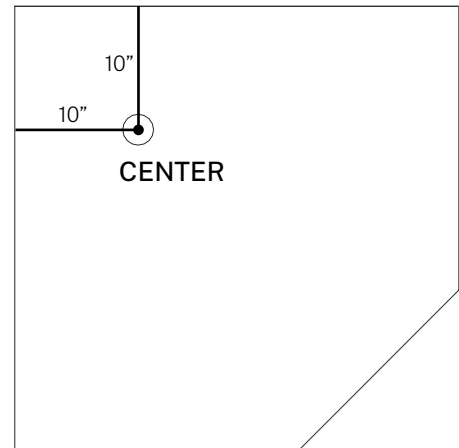

NOTE: Standard Grommet (GRCUT) is automatically added to all CORNER, CURVILINEAR CORNER and EXTENDED CORDER work surfaces and sizes. Standard placement shown above.

3. EXT. CORNER - RIGHT

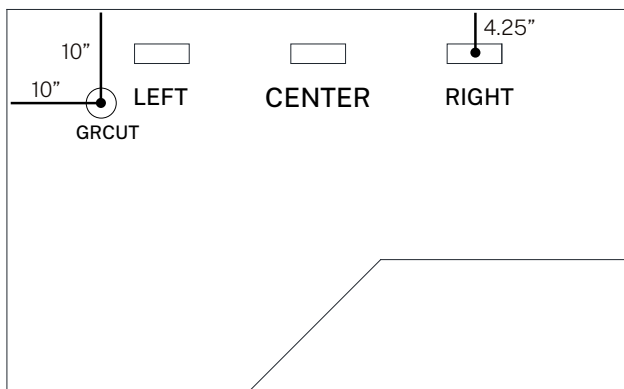

4. EXT. CORNER - LEFT

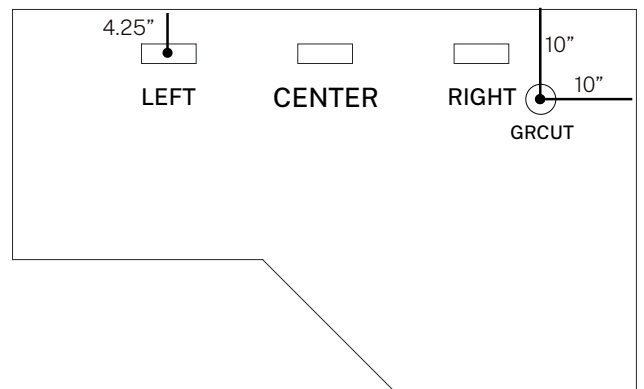

NOTE: Corner grommets (GRCUT) do not come standard on sit-stand base tops (AHCWS, AHCCWS, AHTECCWS) and must be specified separately.

SKU: FLPDMFM



Surface Dimensions: 5.4" x 2.25"
Cutout Dimensions: 5.345" x 1.825"

1. STRAIGHT

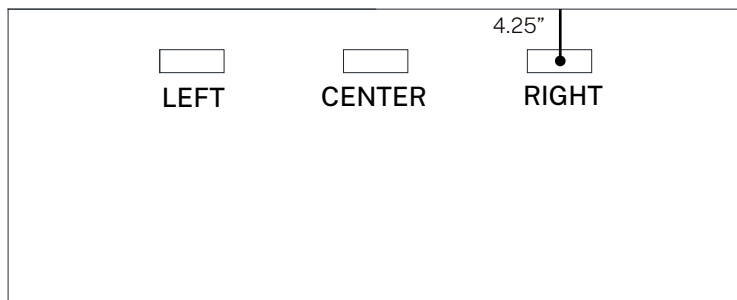

2. CORNER

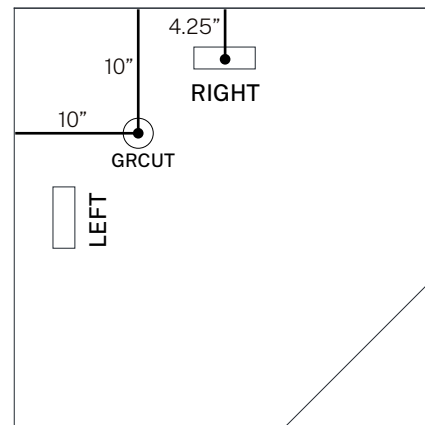

3. EXT. CORNER - RIGHT

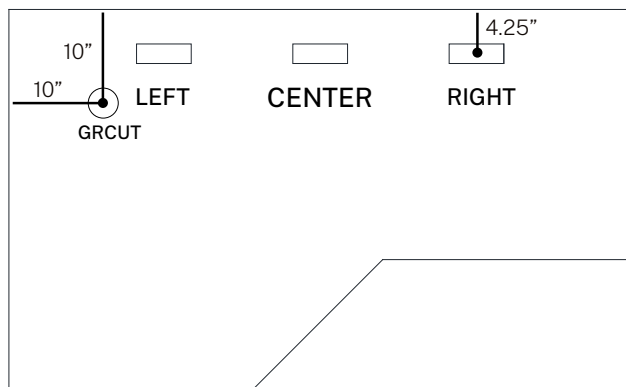

4. EXT. CORNER - LEFT

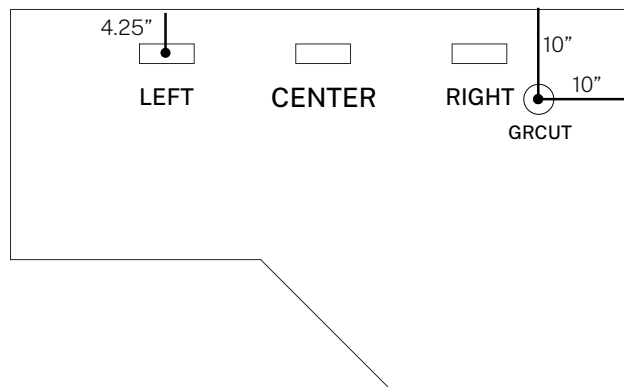

NOTE: Standard Grommet (GRCUT) is automatically added to all CORNER, CURVILINEAR CORNER and EXTENDED CORDER work surfaces and sizes. Standard placement shown above.

SKU: OPS-TV2802-F



Surface Dimensions: 7.1" x 2.13"
Cutout Dimensions: 6.243" x 1.824"

1. STRAIGHT

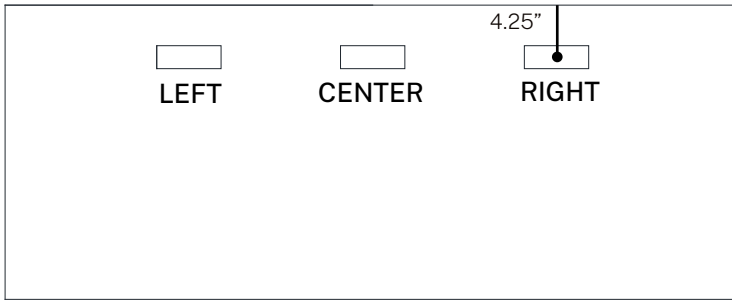

2. CORNER

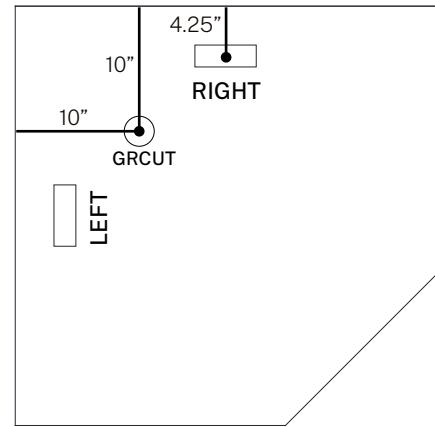

3. EXT. CORNER - RIGHT

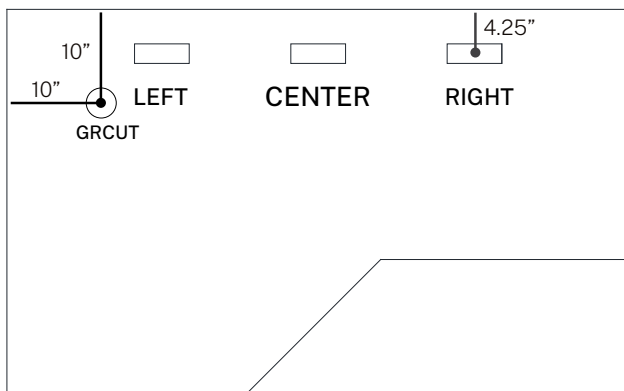

4. EXT. CORNER - LEFT

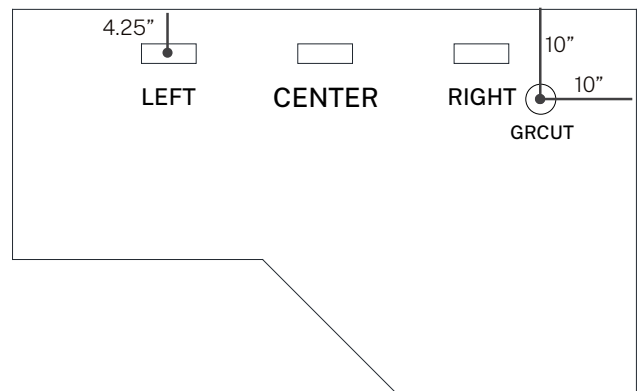

NOTE: Standard Grommet (GRCUT) is automatically added to all CORNER, CURVILINEAR CORNER and EXTENDED CORDER work surfaces and sizes. Standard placement shown above.

SKU: OPS-TVC21101



Surface Dimensions: 8.188" x 2.1"
Cutout Dimensions: 7.556" x 1.784"

1. STRAIGHT

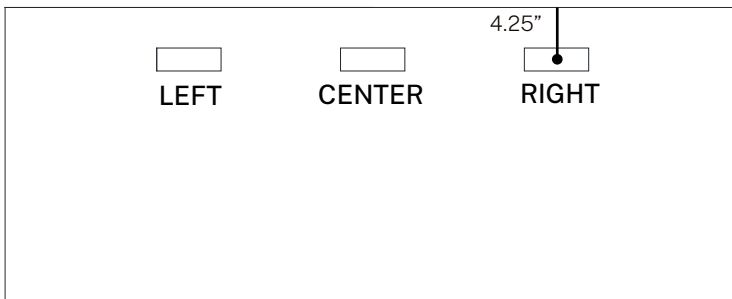

2. CORNER

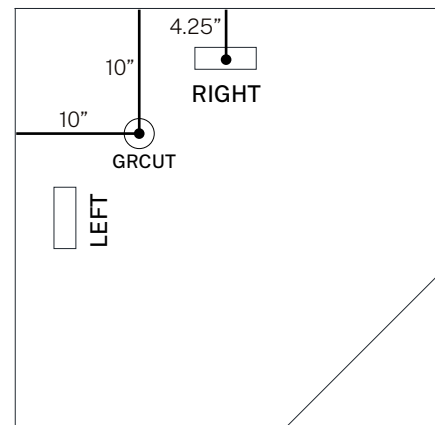

3. EXT. CORNER - RIGHT

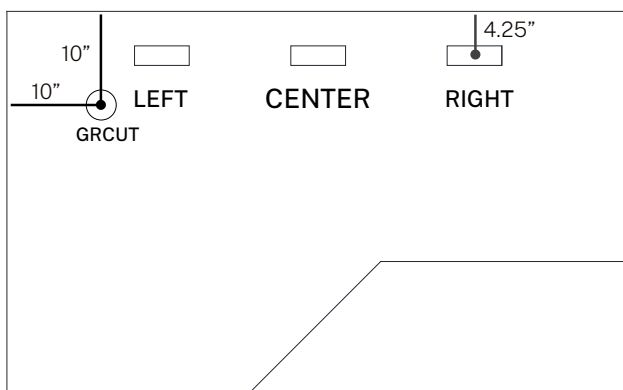

4. EXT. CORNER - LEFT

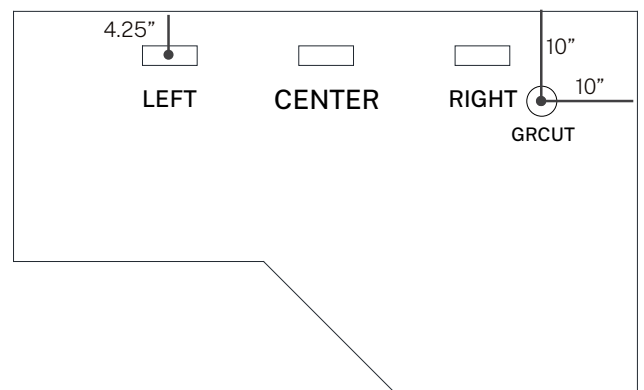

NOTE: Standard Grommet (GRCUT) is automatically added to all CORNER, CURVILINEAR CORNER and EXTENDED CORDER work surfaces and sizes. Standard placement shown above.

SKU: OPS-D270



Surface Diameter: 3.5"
Cutout Diameter: 2.99"

1. STRAIGHT

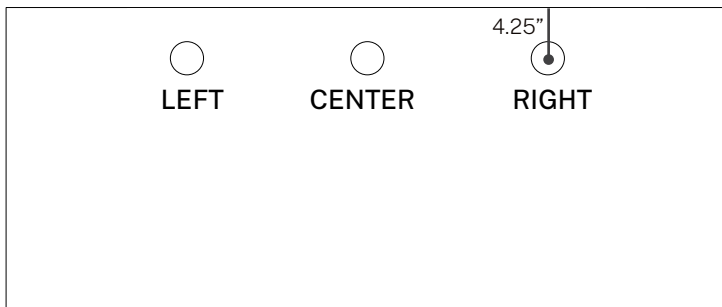

2. CORNER

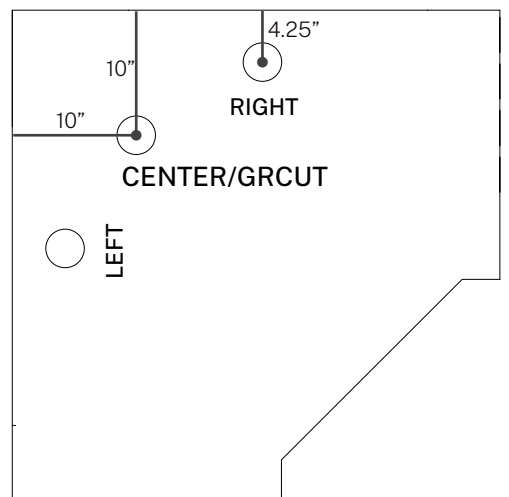

3. EXT. CORNER - RIGHT

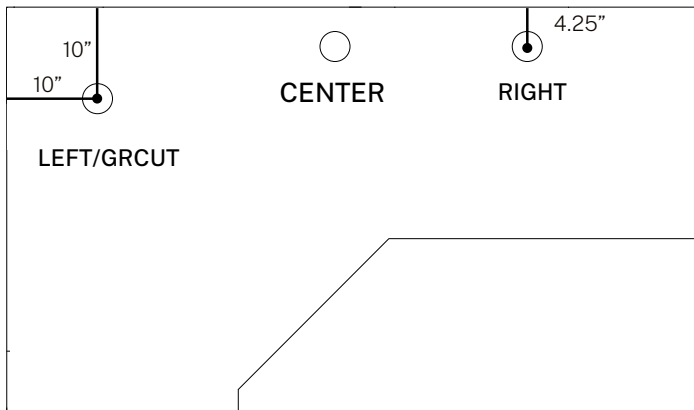

4. EXT. CORNER - LEFT

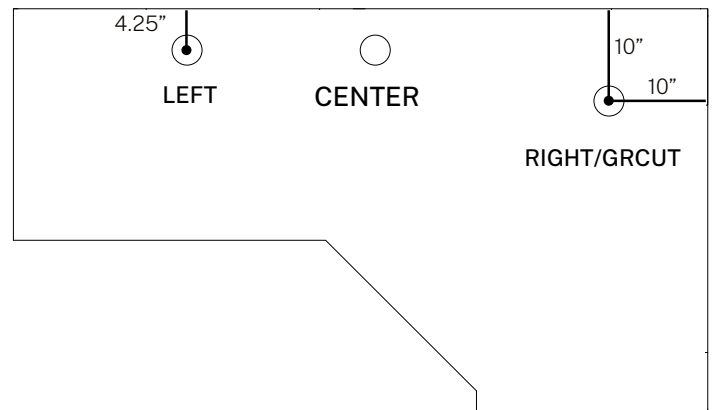

NOTE: Standard Grommet (GRCUT) is automatically added to all CORNER, CURVILINEAR CORNER and EXTENDED CORDER work surfaces and sizes. Standard placement shown above.

SKU: OPS-950.BK



Surface Diameter: 3.5"
Cutout Diameter: 2.99"

1. STRAIGHT

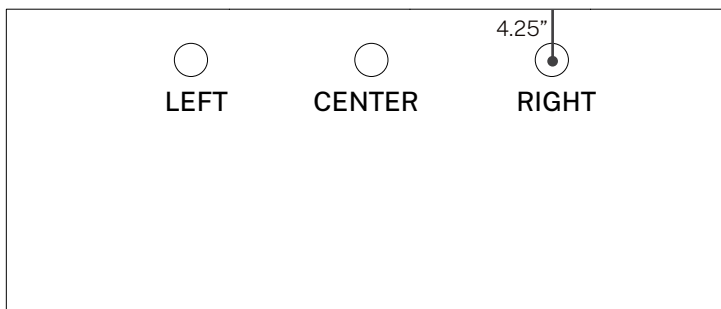

2. CORNER

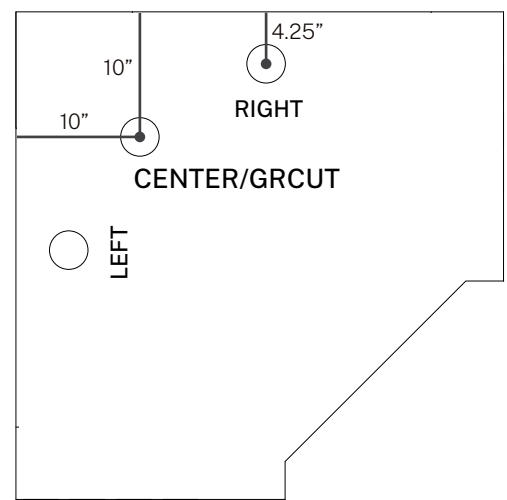

3. EXT. CORNER - RIGHT

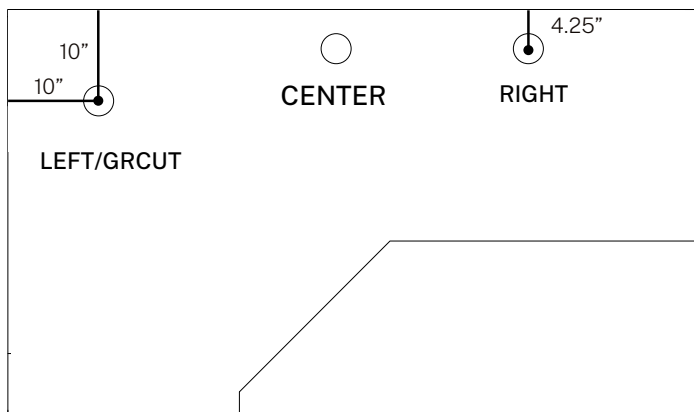

4. EXT. CORNER - LEFT

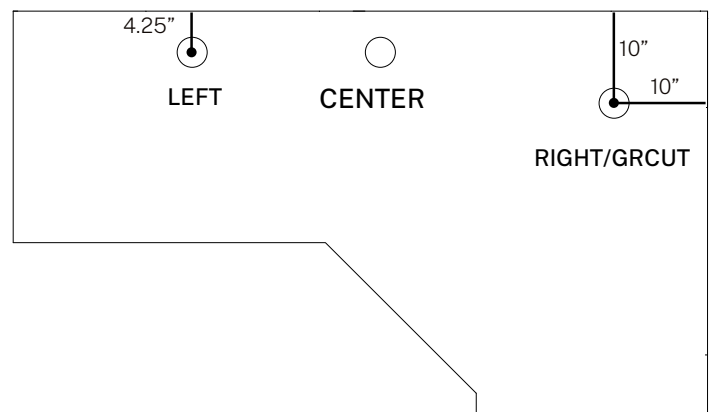

NOTE: Standard Grommet (GRCUT) is automatically added to all CORNER, CURVILINEAR CORNER and EXTENDED CORDER work surfaces and sizes. Standard placement shown above.

SKU: OPS-DOC702.BK



Surface Dimensions: 8.188" x 4.375"
Cutout Dimensions 7.868" x 4.115"

SINGLE

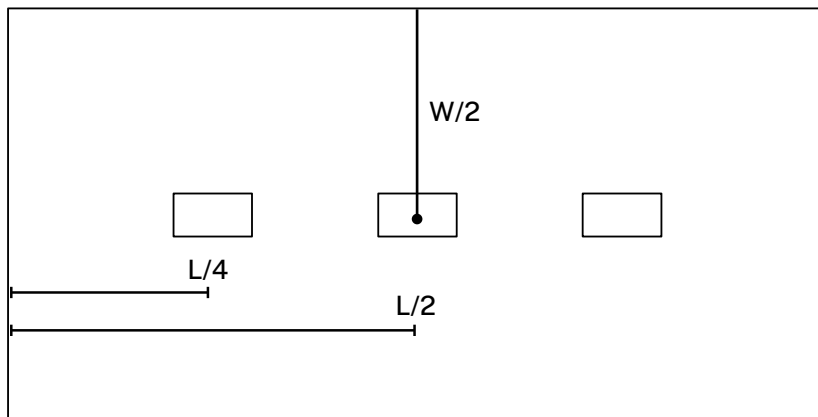

SKU: OPS-DOC704.BK



Available in Black/.BK or Satin/.SA finish

Surface Dimensions: 8.188" x 8.188"
Cutout Dimensions: 7.868" x 7.927"

DUAL

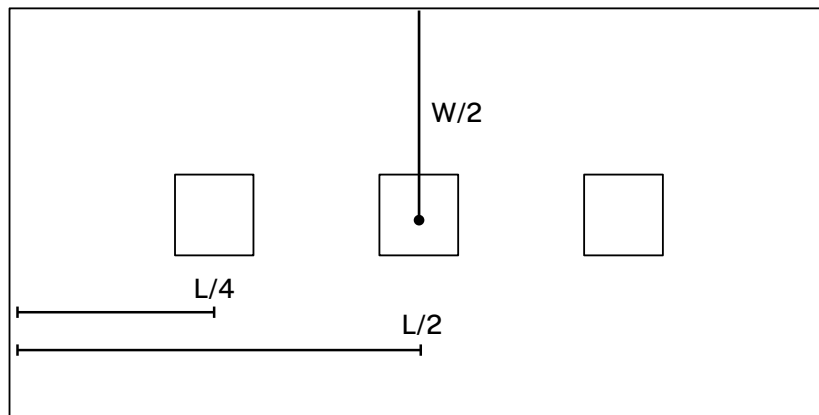

NOTE: To find the center depth of your table, divide the width of the table by 2 (**width/2**)

SIXTY-FIVE WORK SURFACES

Specifying A Work Surface for Sixty-Five

When ordering a work surface for a Sixty-Five workstation, add “65-” to the start of the part number.

A complete listing of our work surface part numbers can be found in our Open Plan Systems Price Book.

Example: If specifying a 30x46 Rectangular Work Surface with standard SKU WS3046,

Why Scallops Are Included With Work Surfaces

Due to distance between panel frames and work surfaces in Sixty-Five, scallop cuts are automatically added to work surfaces to provide support for mounting accessories and cable management.

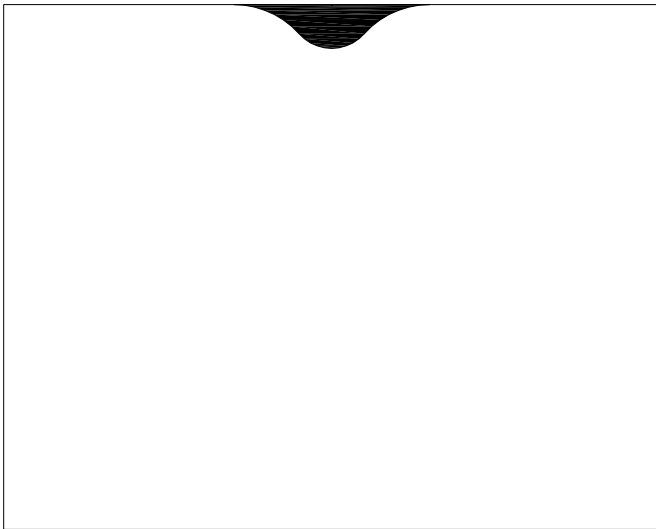

Single scallop cuts are applied to 24”, 30”, 36”, 42”, 48”, 54” surfaces in a rear centered location.

Dual scallop cuts are applied to 60”, 66”, 72”, 78”, 84”, 96” surfaces at left and right rear centered locations.

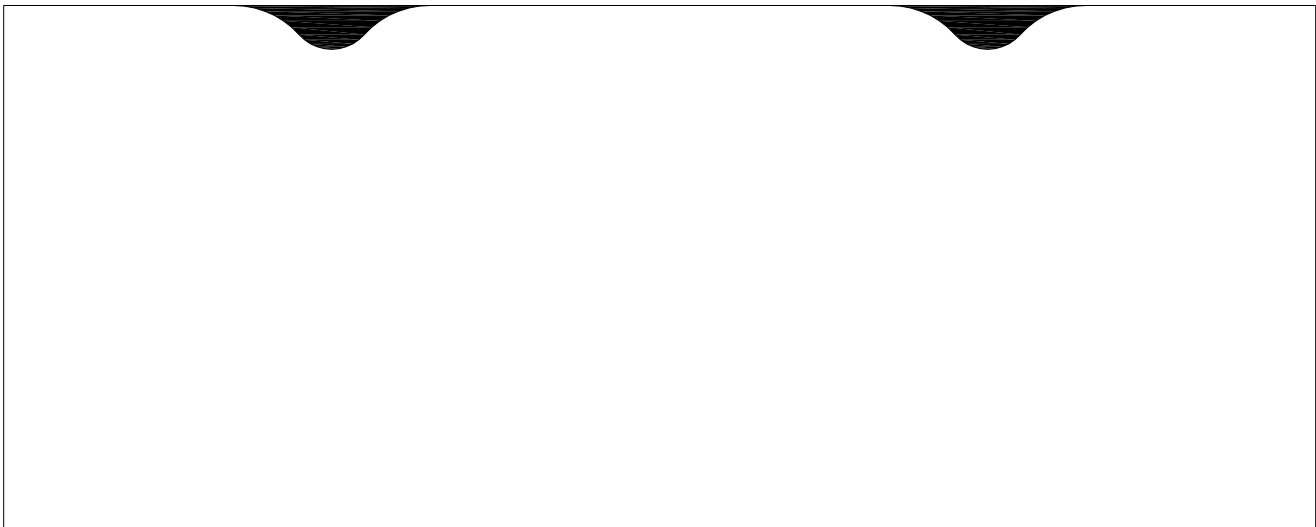

SIXTY FIVE WORK SURFACES

Why Scallops Are Included With Work Surfaces

Due to distance between panel frames and work surfaces in Sixty-Five, scallop cuts are automatically added to work surfaces to provide support for mounting accessories and cable management.

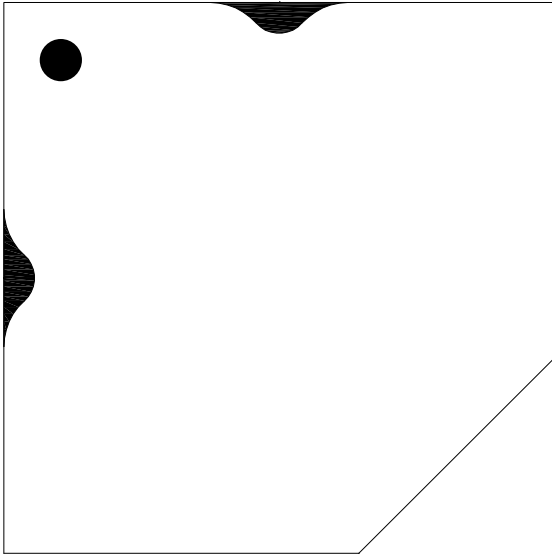

Corner Work Surface

Dual scallop cuts are applied to the corner and curved corner surfaces left and right of the rear center location. GRCUT grommet included.

Extended Corner Work Surface

Dual scallop cuts are applied to the extended and extended curved corner surfaces at the left and right rear center locations. GRCUT grommet included.



Peninsula Work Surface

Single scallop cuts are applied to the peninsula surface side center location.

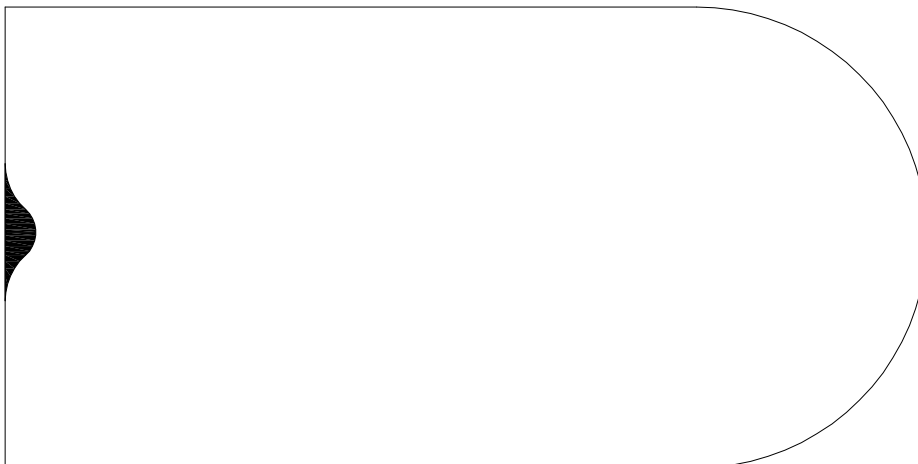

XPAND WORK SURFACES

SCALLOP CUTS

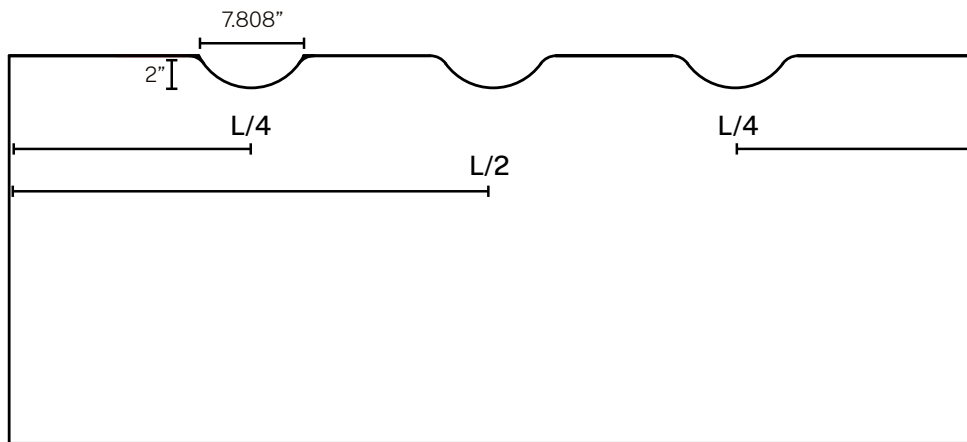

Note: Scallop cuts (SRCUT) available on all sizes as an option (not standard).

XPAND WORK SURFACES LENGTH 60" AND BELOW

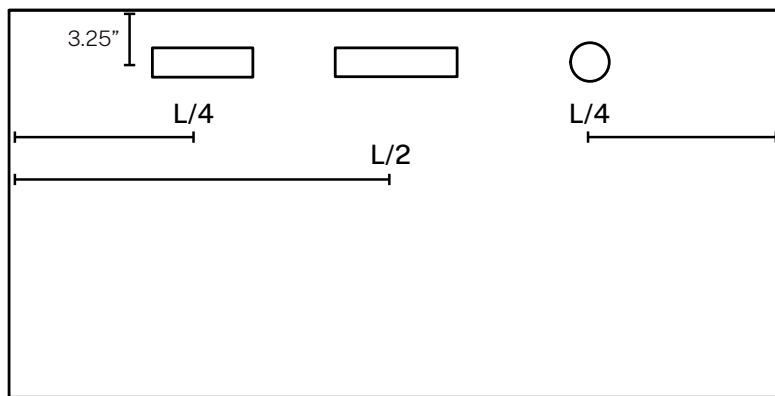

Note: OPS-DOC701/702 are not compatible due to cable tray interference.

XPAND WORK SURFACES LENGTH 61" AND ABOVE



Note: OPS-DOC701/702 and center grommets are not compatible due to cable tray interference.

XPAND WORK SURFACES

120° CORNER TOP

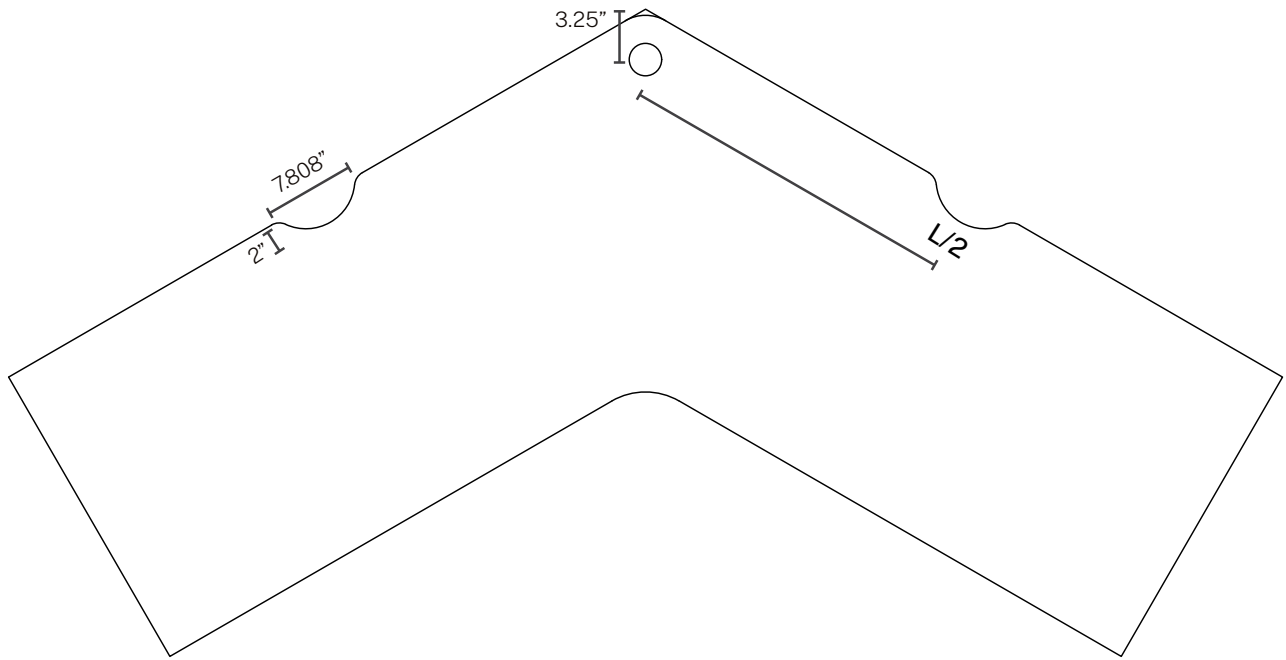

NOTE: Top is only compatible with Grommet (GRCUT) and Scallop (SRCUT).

RACETRACK / RECTANGULAR CONFERENCE TOP

(Racetrack Shown)

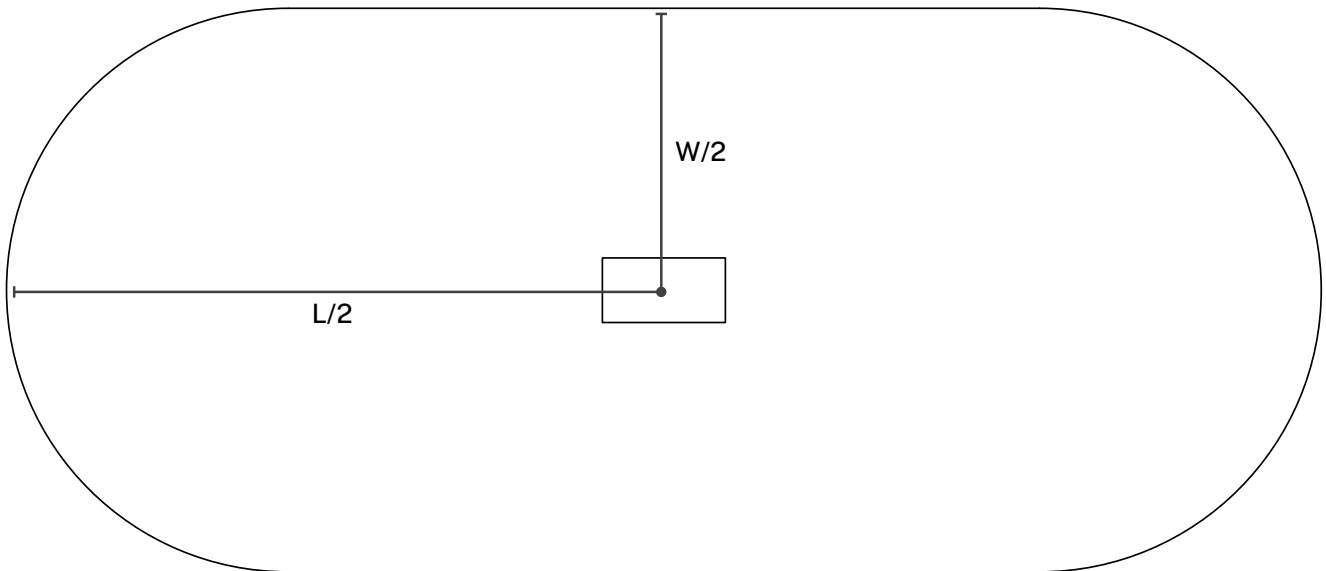

NOTE: 42" and 48" tops available with all power grommets. 36" top excludes OPS-DOC702.

XPAND WORK SURFACES

ALL OTHER POWER GROMMET OPTIONS

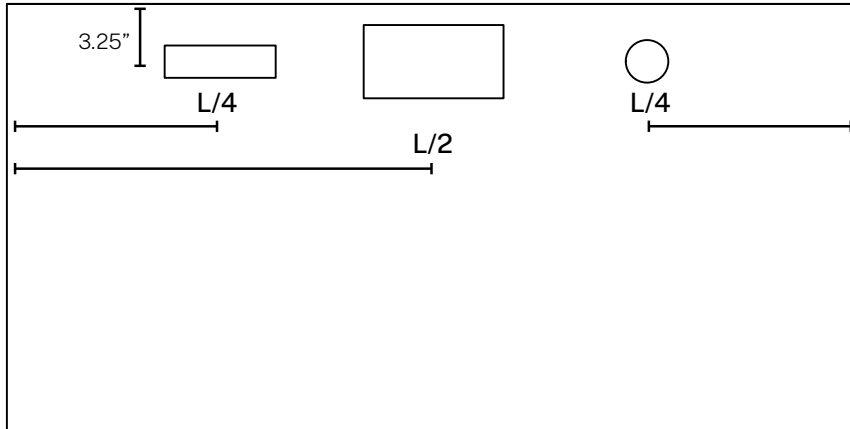

Note: OPS-702 is not compatible available on XP-HA-TXXX tops.