

DTR-LT

Installation Guide

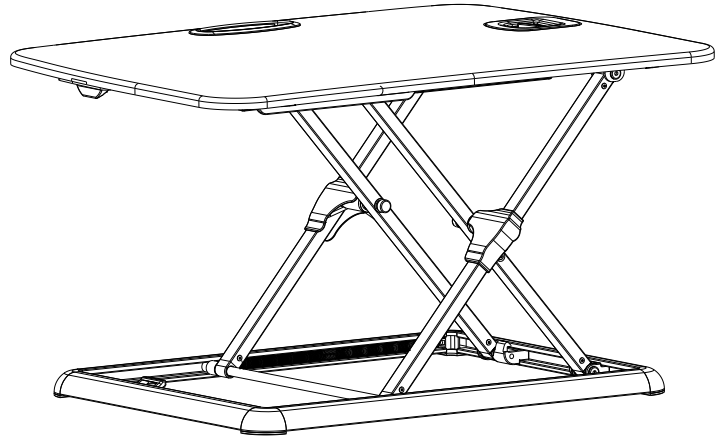

Technical Data

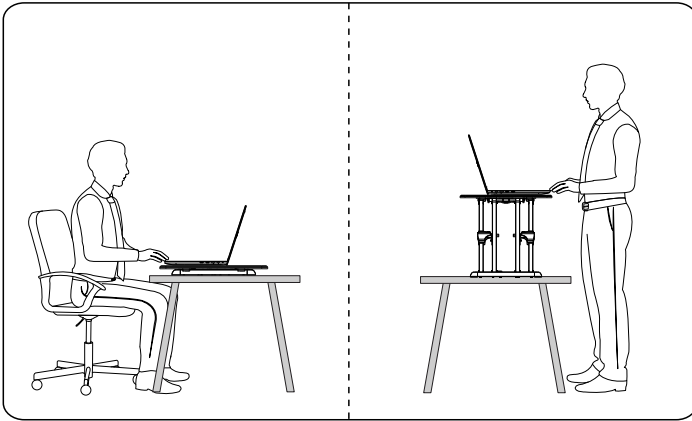
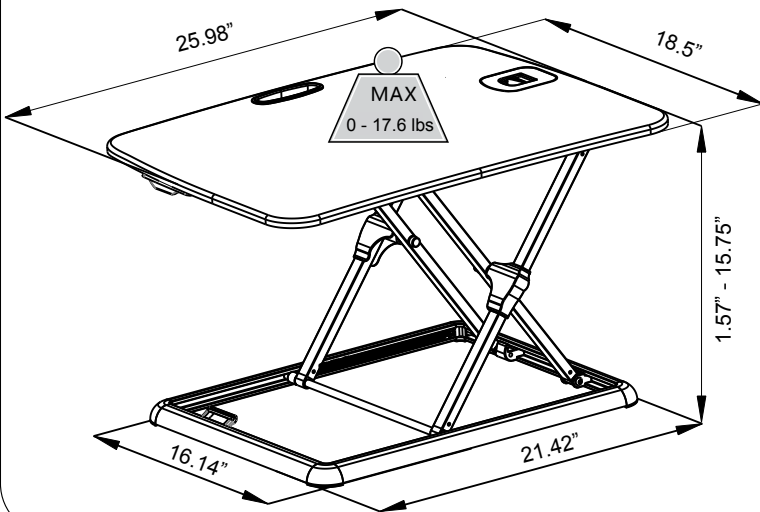

Minimum Table Size:

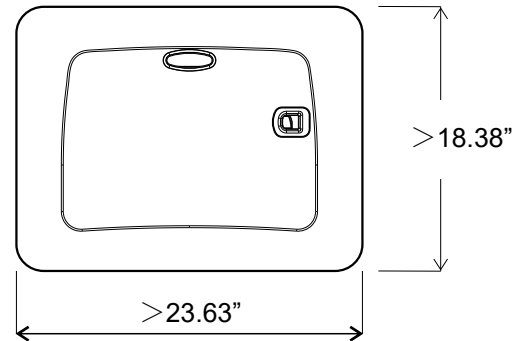

Please do not exceed the maximum WARNING bearing weight.

Loading range	0 - 17.6 lbs
Height adjustment range	1.57" - 15.75"

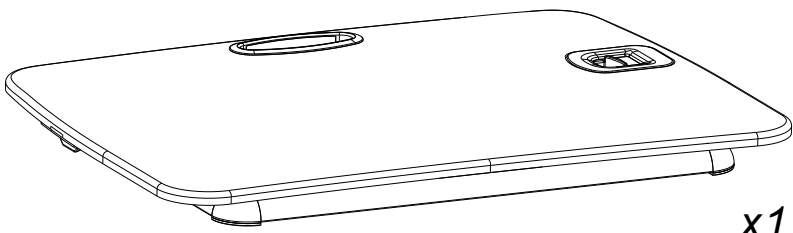

Spare part

NO.	Accessory
A	 <p>x1</p>

TOOLS

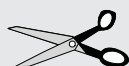

STEP 1

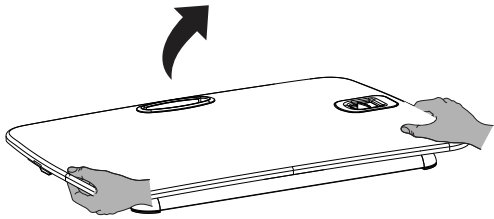

Remove Desk Riser from packing, and place it on a solid work surface.

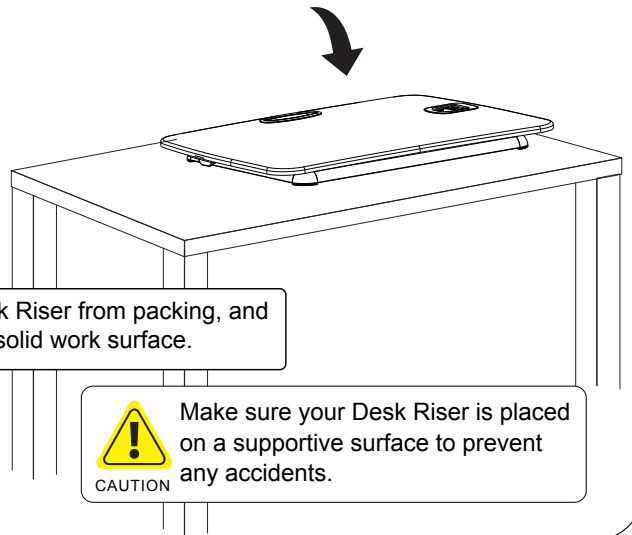

Make sure your Desk Riser is placed on a supportive surface to prevent any accidents.

STEP 2



Please do not put hands near the supporting bars in case of any injuries while the desk is lifting up and down.

Press and hold the switch to adjust your Desk Riser to your preferred height.

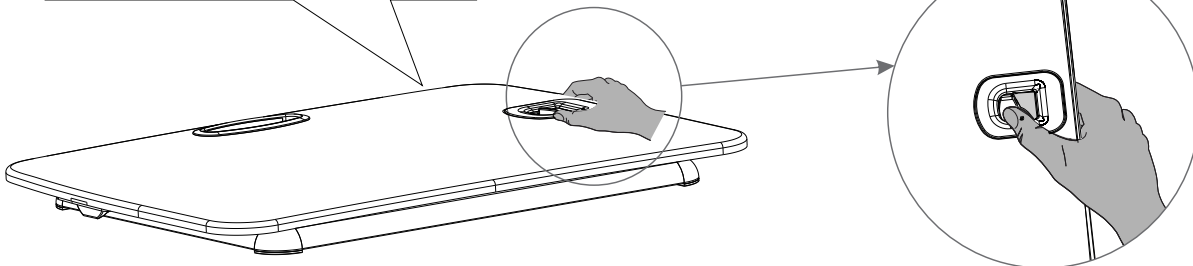

To raise your Desk Riser, press and hold the switch on the surface with your thumb, then lift the Desk Riser while holding both sides of the work surface. Let go of the switch and your Desk Riser will lock into place. To lower your Desk Riser, press and hold the switch on the surface with your thumb, then press down on the Desk Riser while holding both sides of the work surface. Let go of the switch and your Desk Riser will lock into place.

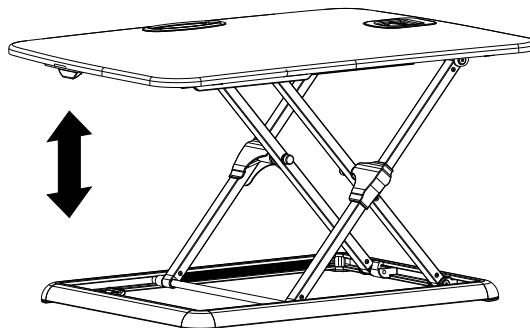

STEP 3

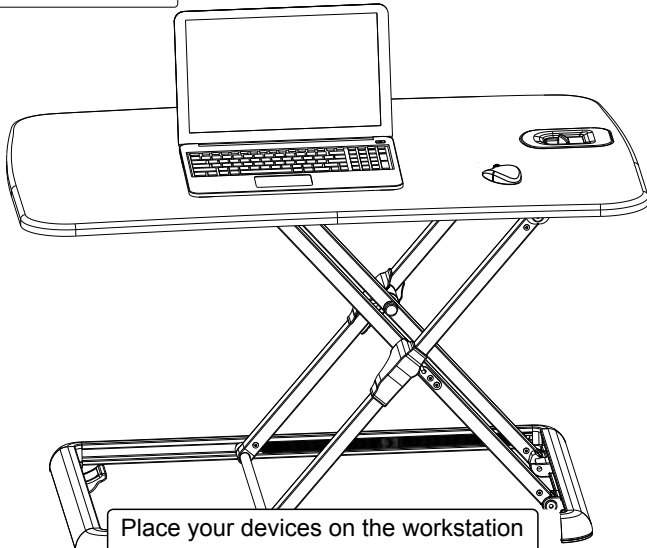

Place your devices on the workstation to test for stability.

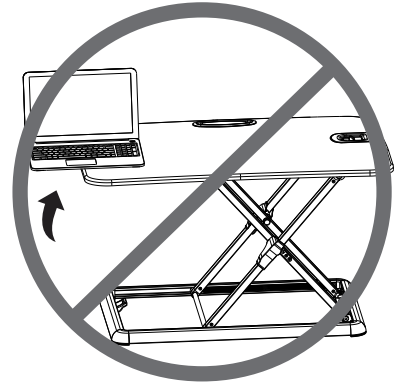

CAUTION

Make sure all equipment is placed safely within the work surface to prevent any damage or injuries.

How to take the workstation safely

1 Close the insurance switch

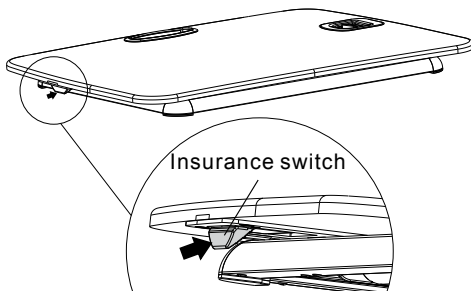

Please press the insurance switch and make sure it is closed to avoid losing its effect before taking it, or it will make workstation flick suddenly. It will decrease the potential risks after carry workstation.

2 Take the workstation

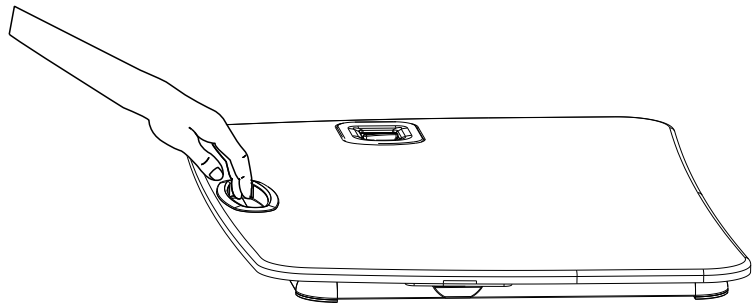



WARNING

Hands Pinching

Do not place your hand near the strut.
Strut's angle will change during the
desktop lifts and it may hurt you.

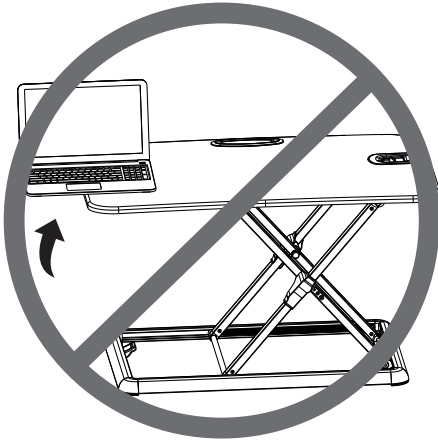

Attention

Make sure all equipment is placed safely
within the work surface to prevent any
damage or injuries.

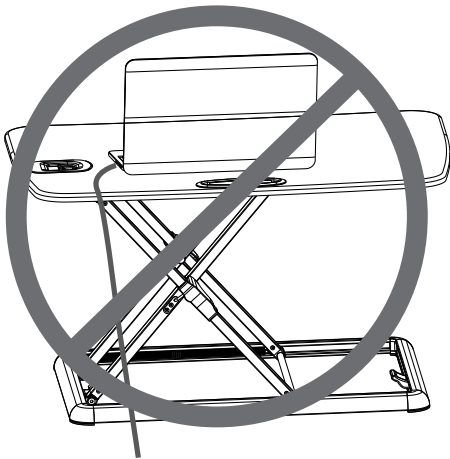

Attention

Please leave enough length of cable for
height adjustment function, or it may hurt
you or cause damage.